

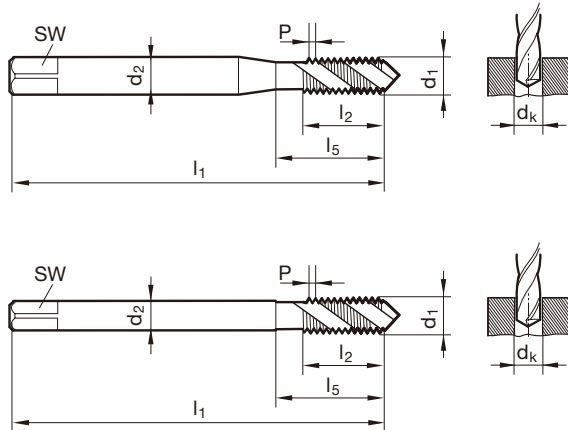

P	M	K	N	S	H
•	•	○	○	○	



鈷領編號

工具材質

公差等級

Surface

Type

Form

392

HSS-E

2BX

A

VA R45

C



DIN 2184-1 DIN376

直徑	柄徑	四方型	下孔徑	全長	刃長	加工長	Code no.
d1xP	d2	SW	dk	l ₁	l ₂	l ₅	
NR.2 - 64	2.80	2.10	1.85	45.00	5.0	14.5	2.184
NR.4 - 48	3.50	2.70	2.40	56.00	6.0	18.0	2.845
NR.6 - 40	4.00	3.00	2.95	56.00	6.5	20.0	3.505
NR.8 - 36	4.50	3.40	3.50	63.00	7.0	21.0	4.166
NR.10 - 32	6.00	4.90	4.10	70.00	8.5	25.0	4.826
NR.12 - 28	6.00	4.90	4.60	80.00	9.0	30.0	5.486
1/4 - 28	7.00	5.50	5.50	80.00	9.0	30.0	6.350
5/16 - 24	8.00	6.20	6.90	90.00	11.0	35.0	7.938
3/8 - 24	10.00	8.00	8.50	90.00	11.0	35.0	9.525
7/16 - 20	8.00	6.20	9.90	100.00	13.0	42.0	11.113
1/2 - 20	9.00	7.00	11.50	100.00	13.0	40.0	12.700
9/16 - 18	11.00	9.00	12.90	100.00	14.0	40.0	14.288
5/8 - 18	12.00	9.00	14.50	100.00	15.0	44.0	15.875
3/4 - 16	14.00	11.00	17.50	110.00	16.0	44.0	19.050
7/8 - 14	18.00	14.50	20.40	125.00	19.0	44.0	22.225
1 - 12	18.00	14.50	23.25	140.00	22.0	50.0	25.400

價格

2,120
2,080
1,860
2,120
1,690
2,190
1,970
2,190
2,220
2,580
2,580
3,940
3,760
4,550
5,910
9,210

