

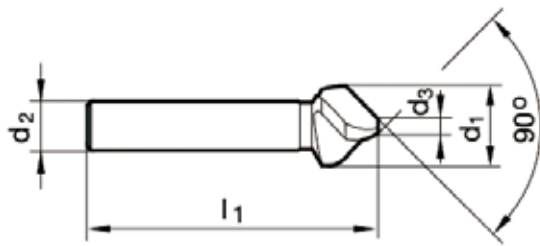

90°倒角刀，凸型切削刃，降低切削阻力60%、避免震刀、面粗度佳 DIN335



材質	HSCO
銼領編號	5500
form	C
表面處理	TiALN
刃數	3

E75

直徑 mm範圍 6.3~31.00						 價格
d1 mm	d2 mm	d3 mm	l1 mm	應用於 螺絲倒角		
6.30	5.00	1.50	45	M3	1,400	
8.00	6.00	2.00	50	M4	1,660	
8.30	6.00	2.00	50	M4	1,580	
10.00	6.00	2.50	50	M5	1,680	
10.40	6.00	2.50	50	M5	1,730	
11.50	8.00	2.80	56	M6	1,960	
12.40	8.00	2.80	56	M6	1,760	
15.00	10.00	3.20	60	M8	2,130	
16.50	10.00	3.20	60	M8	2,130	
19.00	10.00	3.50	63	M10	3,100	
20.50	10.00	3.50	63	M10	3,010	
23.00	10.00	3.80	67	M12	4,560	
25.00	10.00	3.80	67	M12	4,000	
31.00	12.00	4.20	71	M16	6,500	

90°倒角刀，凸型切削刃，降低切削阻力60%、避免震刀、面粗度佳 DIN335

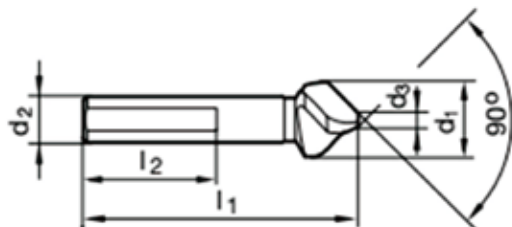

材質	HSCO
銼領編號	5501
form	C
表面處理	TiALN
刃數	3



12側固面長度皆為30mm，有三個側固面，供三爪鑽夾使用

直徑 mm範圍 6.3~31.00						 價格
d1 mm	d2 mm	d3 mm	l1 mm	應用於 螺絲倒角		
6.30	5.00	1.50	45	M3	1,500	
8.00	6.00	2.00	50	M4	1,780	
8.30	6.00	2.00	50	M4	1,690	
10.00	6.00	2.50	50	M5	1,800	
10.40	6.00	2.50	50	M5	1,850	
11.50	8.00	2.80	56	M6	2,110	
12.40	8.00	2.80	56	M6	1,890	
15.00	10.00	3.20	60	M8	2,290	
16.50	10.00	3.20	60	M8	2,290	
19.00	10.00	3.50	63	M10	3,320	
20.50	10.00	3.50	63	M10	3,230	
23.00	10.00	3.80	67	M12	4,900	
25.00	10.00	3.80	67	M12	4,290	
31.00	12.00	4.20	71	M16	6,970	

E76

加長型

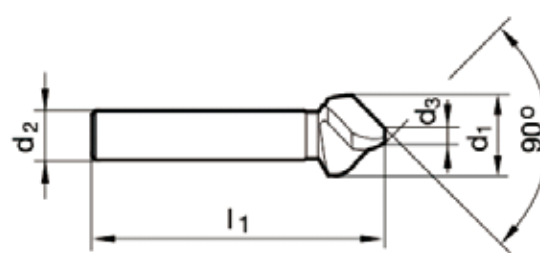
材質	HSC0
鈔領編號	5503
form	C
表面處理	TiALN
刃數	3

直徑 mm範圍 6.3~31.00					
					
d1 mm	d2 mm	d3 mm	l1 mm	應用於 螺絲倒角	價格
6.30	5.00	1.50	104	M3	2,060
8.30	6.00	2.00	105	M4	2,320
10.40	6.00	2.50	107	M5	2,540
12.40	8.00	2.80	108	M6	2,600
16.50	10.00	3.20	111	M8	3,140
20.50	10.00	3.50	114	M10	4,430
25.00	10.00	3.80	118	M12	5,900
31.00	12.00	4.20	140	M16	9,580

**90°倒角刀，凸型切削刃，降低切削阻力60%、避免震刀、面粗度佳 DIN335**



材質	HSCO
銼領編號	5538
柄部	直柄
表面處理	TiALN

E77

無側固面，詳細規格請參考#5500

直徑 mm 範圍	價格
<b>6.3/ 8.3/ 10.4/ 12.4/ 16.5/ 20.5 六支一組</b>	9,520

**90°倒角刀，凸型切削刃，降低切削阻力60%、避免震刀、面粗度佳 DIN335**



材質	HSCO
銼領編號	5539
柄部	3平面
表面處理	TiALN

柄部3平面式，配合3爪鑽夾使用，詳細規格請參考 #5501

直徑 mm 範圍	價格
<b>6.3/ 8.3/ 10.4/ 12.4/ 16.5/ 20.5 六支一組</b>	10,210